



### The Lynx<sup>®</sup> Television Network

- **Distributes up to 528 digital channels on Cat 5 or Cat 6 cable**
- **Increases flexibility for moves, adds and changes**
- **Excellent for CATV, SMATV, or off-air television distribution**
- **Improves reliability**
- **Simplifies cabling requirements**
- **Creates a technology bridge to IPTV**

The Lynx Television Network simultaneously delivers up to 176 HDTV channels, 528 standard digital channels, or 134 analog channels on Cat 5 or Cat 6 cable. Frequency capabilities are 5 MHz to 860 MHz.

simplifies installation, standardizes the wiring, and reduces maintenance requirements.

A Lynx hub in the wiring closet converts an unbalanced coaxial signal into eight or sixteen balanced signals transmitted on twisted pair cables. At the point of use a wallplate F or single port converter changes the signal back to coaxial form.

The Lynx Network increases system flexibility because moves, adds, and changes are easy with Cat5/6 cable.

A homerun wiring design improves reliability because there are no taps or splitters between the distribution hub and the TV.

The Lynx Network also provides a “technology bridge” to IPTV by using the same infrastructure that IPTV will use.

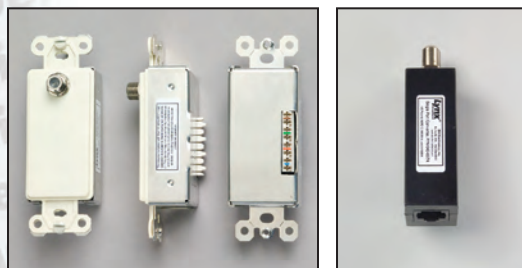

Wallplate F

Single port converter

A patented RF balun is the centerpiece of the Lynx design. A pair of send / receive baluns delivers a clean RF signal to each TV (on pair four). The baluns use an RF technology that delivers HD, digital, and analog channels on network cables without using any bandwidth on the network itself.

The Lynx Network simplifies cable requirements by reducing the need for coax. Now television, phone, and data can all be delivered on twisted pair cables. This

The hubs and point of use converters do not require external power, and are bi-directional. External RF amplifiers compensate for cable and insertion losses.

# Applications

For use in hospitals, schools, universities, hotels, corporate, MDU, and residential applications.

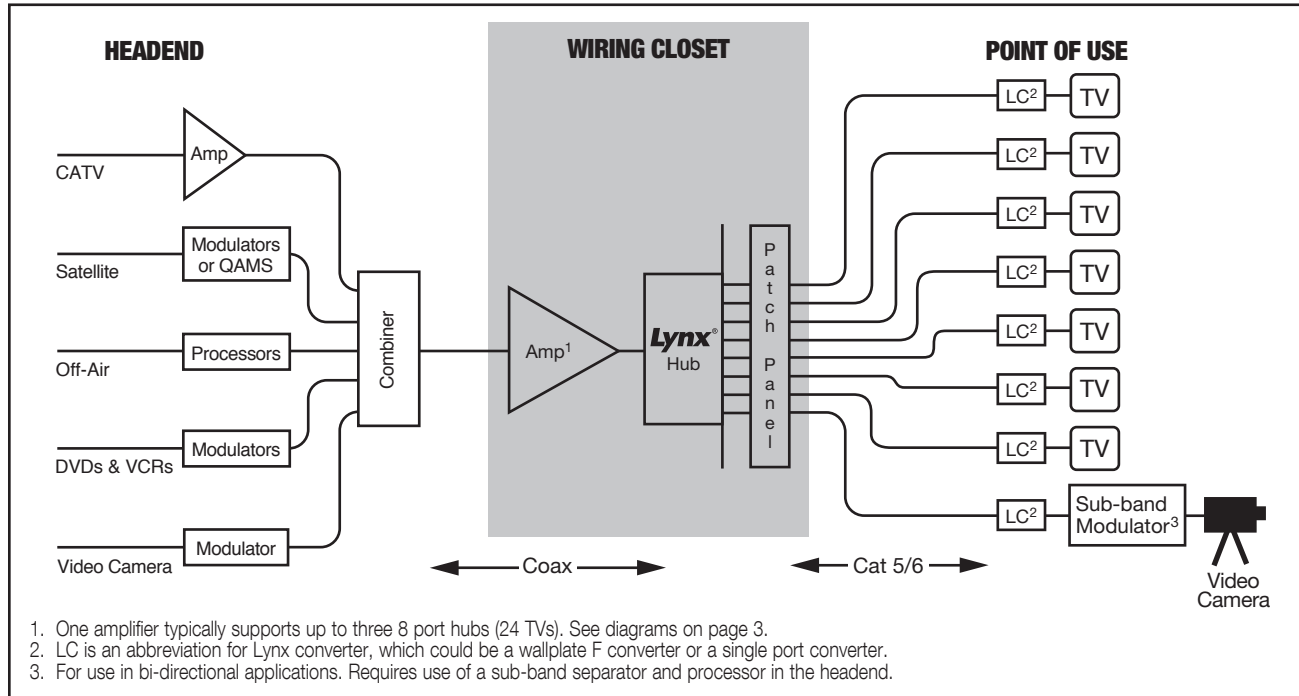

# Equipment Specifications and Options

|   |                  |             |   |                            |                                    |
|---|------------------|-------------|---|----------------------------|------------------------------------|
| <b>Frequency range</b>  | 5 MHz to 860 MHz |             | <b>Insertion loss for hub and converter<sup>1</sup></b> |                            | <13 dB @ 5 MHz<br><19 dB @ 860 MHz |
| <b>Distance capabilities</b><br>(assumes 41 dB to hub for HD and digital channels and 49 dB to hub for analog channels) | <b>Meters</b>    | <b>Feet</b> | <b>Digital channels (1 MHz)</b>                         | <b>HD channels (3 MHz)</b> | <b>Analog channels (6 MHz)</b>     |
|   | 90               | 295         | 288   | 96                         | 78                                 |
|   | 80               | 260         | 372   | 124                        | 99                                 |
|   | 67               | 220         | 528   | 176                        | 134                                |

1. For a free interactive design model that calculates cable and insertion losses and predicts signal strength at the TV e-mail [info@lynxbroadband.com](mailto:info@lynxbroadband.com).

|  | Part Number              | Width   | Height | Depth | Emission Testing        |                                      |
|--|--------------------------|---|--------|-------|-------------------------|--------------------------------------|
| <b>LT hub with rackmount plate</b>               |                          |   |        |       |                         |                                      |
| 16 port LT hub <sup>1</sup>                      | 1U 040-0102 <sup>1</sup> | 19.0"   | 1.75"  | 4.5"  | FCC Part 15 Class A     |                                      |
| 8 port LT hub <sup>1</sup>                       | 1U 040-0101 <sup>1</sup> | 19.0"   | 1.75"  | 4.5"  | FCC Part 15 Class A     |                                      |
| <b>LT hub without rackmount</b> (mounts on wall) |                          |   |        |       |                         |                                      |
| 8 port LT hub <sup>1</sup>                       | 040-0090 <sup>1</sup>    | 6.2"  | 1.4"   | 4.5"  | FCC Part 15 Class A     |                                      |
| 4 port LT hub <sup>1</sup>                       | 040-0217 <sup>1</sup>    | 3.3"  | 1.2"   | 3.7"  | FCC Part 15 Class A     |                                      |
| <b>LC converters</b>                             |                          |   |        |       |                         |                                      |
| Single port converter                            | 040-0074                 | .9"   | .9"    | 3.3"  | FCC Part 15 Class A & B |                                      |
| Wallplate F (light almond)                       | 040-0232                 | Fits in a light almond wallplate ring (PN 809-1663)             |        |       |                         |                                      |
| Wallplate F (white)                              | 040-0237                 | Fits in a white wallplate ring (PN 809-1678)                    |        |       |                         |                                      |
| <b>Port terminators<sup>2</sup></b>              | <b>040-0069</b>          | .5"   | .3"    | .9"   | NA                      |                                      |
| 12" coax jumper cable                            | 180-0455                 | connects the single port converter to the F connector on the TV |        |       |                         |                                      |
| <b>Rackmount plates</b>                          |                          |   |        |       |                         |                                      |
| 16 port (two 8s)                                 | 809-1274                 | 19.0"   | 1.75"  | .1"   | NA                      |                                      |
| 20 port (five 4s)                                | 809-1647                 | 19.0"   | 1.75"  | .1"   | NA                      |                                      |
| <b>Amplifier<sup>1</sup></b>                     | 35dB gain, 1GHz          | 180-0465  | 5.38"  | 7.63" | 3"                      | 20dB slope, 42MHz active return path |

1. **Amplification is usually needed upstream of each hub.** One amplifier usually serves up to 24 drops in each wiring closet. See diagram on next page.  
 2. **Port terminators are required for all unused ports** in order to prevent electromagnetic emissions. An eight port hub serving six TVs has two unused ports that must be terminated.

U.S. patents 5,495,212 5,633,614 6,150,896

## System Design Suggestions

One amplifier can usually support up to 24 drops from a given wiring closet, as shown at right below.

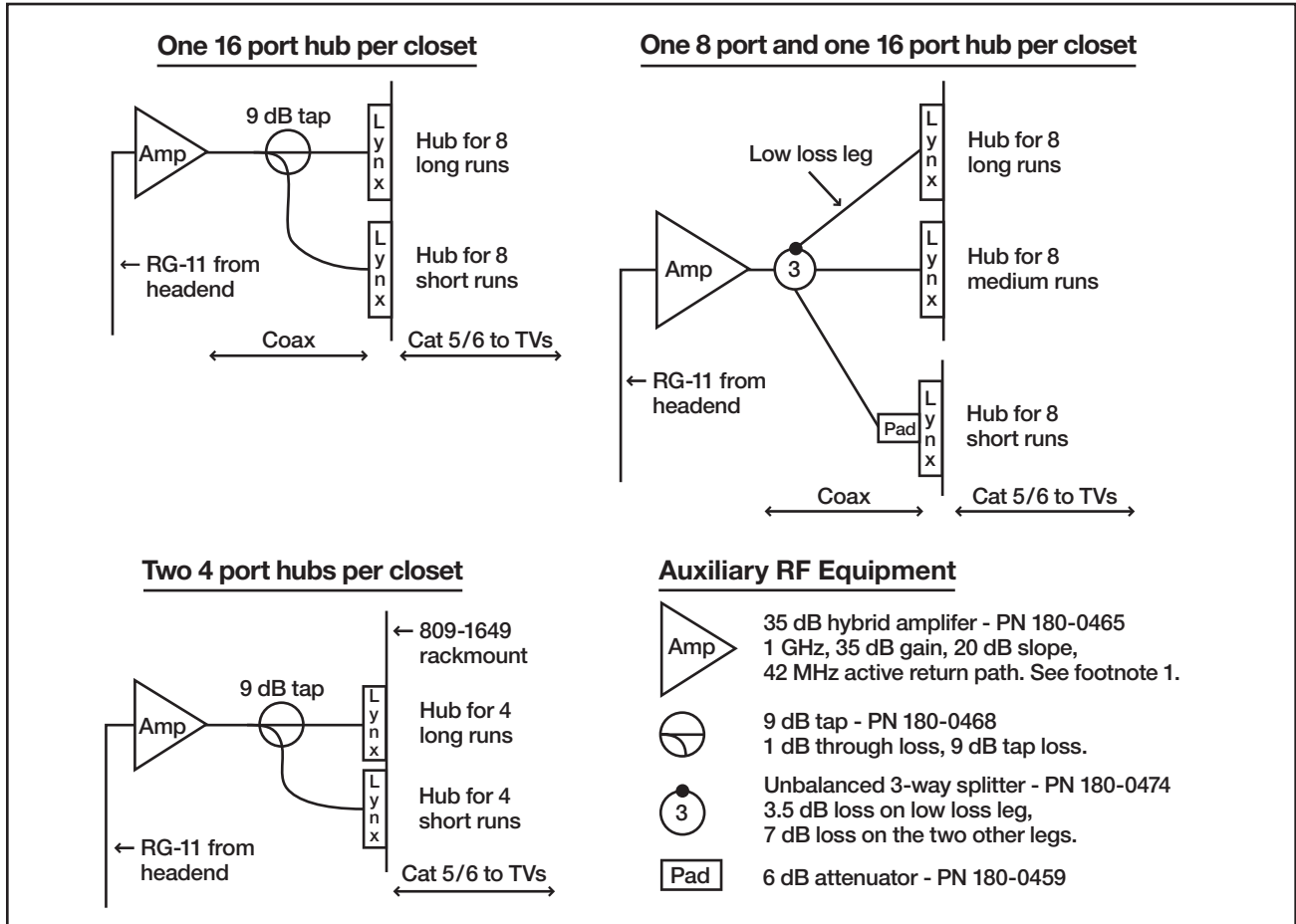

1. Hybrid amplifiers like the 180-0465 are recommended as distribution amps in the wiring closets. If a launch amp is needed in the headend or demarcho, a power doubling amplifier is recommended.

## Residential Packages

Residential packages are available for applications with one to four TVs. These packages are capable of delivering the full range of HD, digital, and analog channels. They include a bi-directional amplifier, Lynx converters, connectors, coax jumpers, and patch cords.

Two types of packages are available. Packages with a 20 dB amp are typically used to deliver "basic" cable TV service with frequencies up to 550MHz. They can also deliver the "channel 3" output from the F connector on a satellite receiver. Packages with a 35 dB amp are typically used to deliver "premium" cable TV packages or off-air television with frequencies up to 860 MHz. The table below shows distance capabilities for each package.

| Number of TVs  | Part Number | Amp   | Distance with basic cable TV (≤ 550 MHz) | Distance with premium cable TV or off-air TV (≤ 860 MHz) | Splitter | Single Port Converters (spc) | 4 Port Hub | Cat 5 Jumpers | Coax Jumpers |
|--|-------------|-------|--|--|----------|------------------------------|------------|---------------|--------------|
| <b>20 dB packages - typically used for basic cable TV</b>                  |             |       |  |  |          |                              |            |               |              |
| 1  | 040-0218    | 20 dB | ≤ 145 ft.                                | ≤ 100 ft.  | -        | 2                            | -          | 1             | 4            |
| 2  | 040-0219    | 20 dB | ≤ 120 ft.                                | ≤ 80 ft.   | 2 way    | 4                            | -          | 2             | 5            |
| 3  | 040-0220    | 20 dB | ≤ 105 ft.                                | ≤ 65 ft.   | 3 way    | 6                            | -          | 3             | 6            |
| 4  | 040-0221    | 20 dB | ≤ 100 ft.                                | ≤ 60 ft.   | -        | 4                            | 1          | 4             | 7            |
| <b>35 dB packages - typically used for premium cable TV and off-air TV</b> |             |       |  |  |          |                              |            |               |              |
| 1  | 040-0222    | 35 dB | ≤ 210 ft.                                | ≤ 155 ft.  | -        | 2                            | -          | 1             | 3            |
| 2  | 040-0223    | 35 dB | ≤ 185 ft.                                | ≤ 135 ft.  | 2 way    | 4                            | -          | 2             | 4            |
| 3  | 040-0224    | 35 dB | ≤ 170 ft.                                | ≤ 125 ft.  | 3 way    | 6                            | -          | 3             | 5            |
| 4  | 040-0225    | 35 dB | ≤ 165 ft.                                | ≤ 120 ft.  | -        | 4                            | 1          | 4             | 6            |

## Residential Configuration for Two TVs with a 20 dB amp

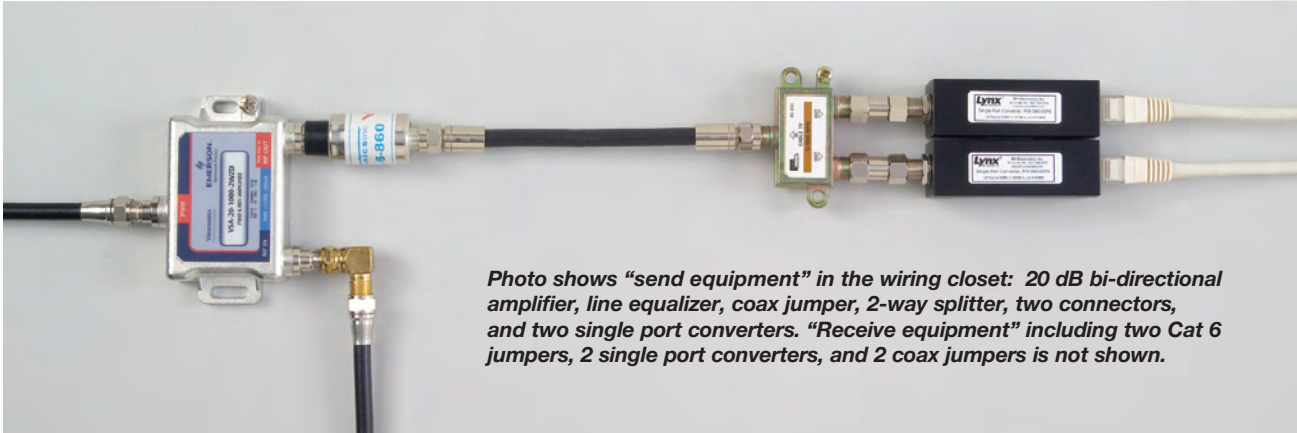

## Residential Configuration for Three TVs

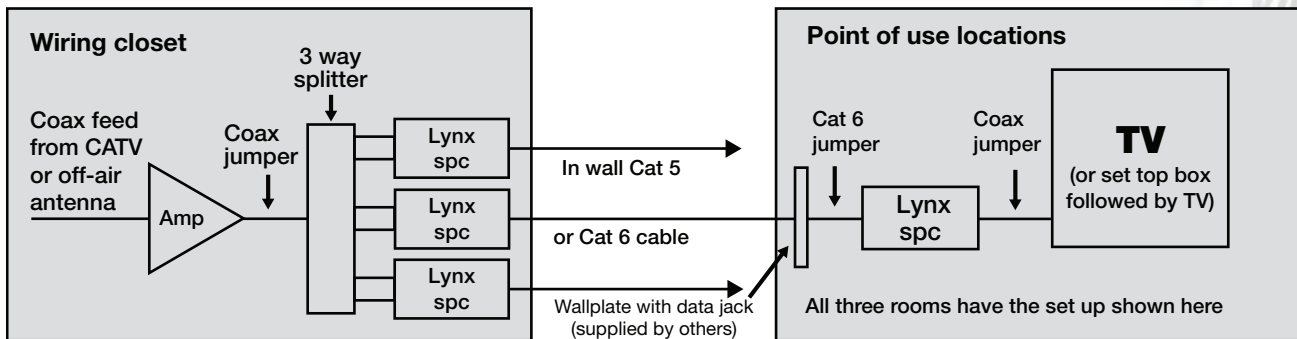

## Residential Configuration for Four TVs with a 35 dB amp

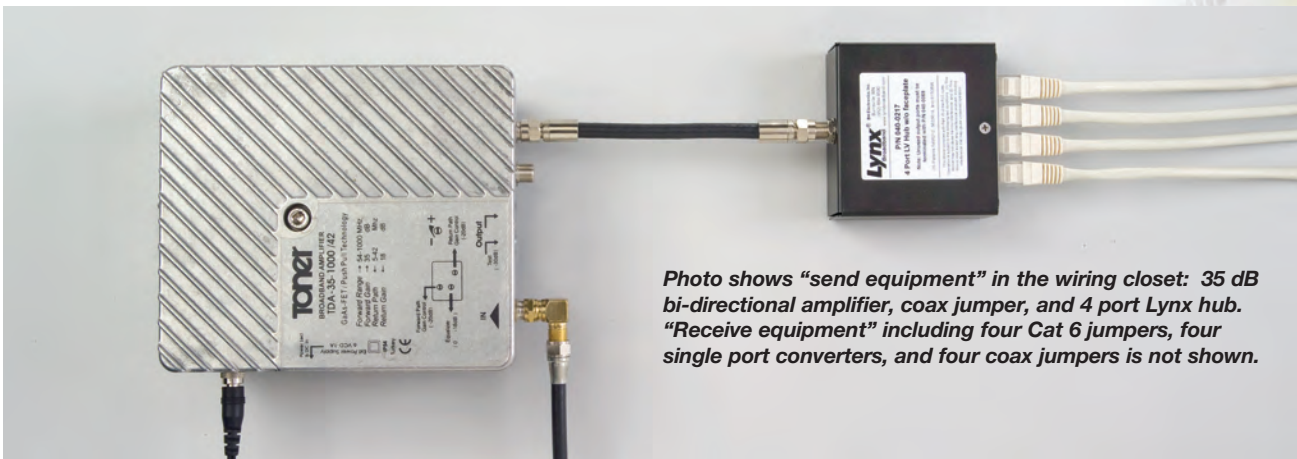

## Purchasing Residential Packages

Residential packages can be purchased on the web at [www.lynxbroadband.com/resi](http://www.lynxbroadband.com/resi)

ISO 9001 Certified Quality System

**Lynx**<sup>®</sup>  
Broadband

[www.lynxbroadband.com](http://www.lynxbroadband.com)

**BH Electronics**

12219 Wood Lake Drive • Burnsville, MN 55337 • Phone: 952-894-9590 • Fax: 952-894-9380